



NON-CONTRACTUAL PHOTO. ACTUAL PRODUCT MAY VARY FROM THE ONE SHOWN.

## AT LEADING SIDE REACH

Quality Management System certified by TÜV Rheinland.  
AXIONLIFT is a company committed to quality.



833-34FLYAX  
[axionlift.com](http://axionlift.com)

## TELESCOPIC ARTICULATING AERIAL DEVICES

### GENERAL SPECIFICATIONS

EQUIPMENT	AT40
Working height <sup>1</sup>	45.0 ft / 13,7 m
Ground to bottom of the platform <sup>1</sup>	40.0 ft / 12,2 m
Maximum side reach	28.5 ft / 8,7 m
Stowed travel height <sup>1</sup>	9.0 ft / 3,0 m
Telescopic boom extension	116 in / 2,9 m
Platform capacity <sup>2/3</sup>	400 lb - 450 lb / 182 kg - 204 kg
Platform dimensions	24 x 30 x 42 in / 610 x 762 x 1070 mm
Rotation	360° continuous infinite

### REACH DIAGRAM

#### AT40

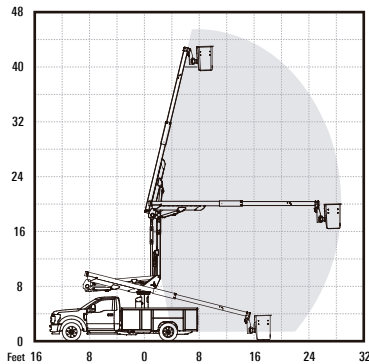

### STANDARD FEATURES

- Emergency stop valves at the upper and lower control stations
- End-Mount platform
- Lower controls with override to the platform
- 4 Function Single Hand Control
- Automatic Hydraulic Platform Leveling System
- Gear box + slewing drive rotation
- Hydraulic oil level and thermometer
- Self-lubricating bushing
- Leveling system and hoses fully embedded inside booms
- Holding valves integrated in hydraulic cylinders
- Insulated 46 kV Category C Chassis Insulating System (Lower Boom)
- Liner
- Capacity: 400 lb / 450 lb (182 kg / 204 kg)
- Hydraulic tool circuit at platform
- Bucket rotator 180°
- Engine Start/Stop at platform
- Electric emergency pump at platform
- Hydraulic bucket tilt
- Quick coupling for working pressure measurement
- Vinyl platform and insert cover
- Mounting brackets & stationary set-ups
- AXIONLIFT meets or exceeds ANSI A92.2 standards
- Certified under ISO 9001 by TÜV Rheinland

### OPTIONS

- Front Outrigger with Interlock System
- Front & Rear Outrigger with Interlock System

1. Based on a chassis frame height of 1016 mm (40 in). 2. According to vehicle's GVW. 3. Recommended single platform.

